

企业文化

CORPORATE CULTURE

企业使命

CORPORATE MISSION

源于匠心，臻于至善。

Originating from ingenuity/achieving perfection.

企业愿景

ENTERPRISE VISION

精益求精，铸造品质典范。

Keep improving, casting quality model.

企业精神

ENTERPRISE SPIRIT

求实、创新、超越自我。

Realistic, innovative and self-transcendence.

企业价值观

CORPORATE VALUES

质量第一、诚信为本。

Quality first, integrity-based.

经营理念

BUSINESS PHILOSOPHY

用户至上，用心服务。

Customer first, service attentively.

HONOR 荣誉证书

CERTIFICATE



荣誉见证品质，资质彰显实力！

荣誉是社会对我们企业的认可，也认证了我们一如既往地高品质的不懈追求。

Honor witnesses quality, qualification shows strength
Honoris the recognition of our company by the society
It is also our unremitting pursuit of high quality as always



CQC 证书



UL 证书



CUL 证书



GS 证书



CE 证书



UKCA 证书



SAA 证书



ISO9001 证书



ROSH 证书



专利证书

THE TRUST OF CUSTOMERS

STEMS FROM THE PURSUIT OF HIGH STANDARDS

客户的信任 -- 源于对高标准追求

MULTI 多速调节风机系列

MULTI SPEED REGULATING FAN SERIES

1HP-1.5HP

1.5HP-2HP

2.5HP-3HP



MAX 风机系列

MAX SERIES

3HP 风机系列

2HP 风机系列



技术参数 TECHNICAL PARAMETERS

	1HP-1.5HP 多速调节风机系列		1.5HP-2HP 多速调节风机系列		2.5HP-3HP 多速调节风机系列	
型号 Model	S-U12 MULTI	S-K12 MULTI	S-U15 MULTI	S-K15 MULTI	S-U20 MULTI	S-K20 MULTI
功率 Power	1HP-1.5HP	1HP-1.5HP	1.5HP-2HP	1.5HP-2HP	2.5HP-3HP	2.5HP-3HP
电压 Voltage	110V-120V	220V	110V-120V	220V	110V-120V	220V
频率 Frequency	60Hz	60Hz	60Hz	60Hz	60Hz	60Hz
压力 Pressure	2350Pa-2700Pa	2350Pa-2700Pa	2700Pa-2900Pa	2700Pa-2900Pa	3100Pa-3300Pa	3100Pa-3300Pa
流量 Flow	890m ³ /h-980m ³ /h	890m ³ /h-980m ³ /h	980m ³ /h-1080m ³ /h	980m ³ /h-1080m ³ /h	1190m ³ /h-1300m ³ /h	1190m ³ /h-1300m ³ /h
线长 Cord Length	3M	3M	3M	3M	3M	3M
认证 Certification	UL/CUL		UL/CUL		UL/CUL	
净重 N.W	10KG	10KG	11KG	11KG	12KG	12KG
毛重 G.W	11KG	11KG	12KG	12KG	13KG	13KG
包装尺寸 Packaging	41.8*30.8*46CM	41.8*30.8*46CM	41.8*30.8*46CM	41.8*30.8*46CM	41.8*30.8*46CM	41.8*30.8*46CM

技术参数 TECHNICAL PARAMETERS

	3HP 风机系列		2HP 风机系列		
型号 Model	S-U20 MAX	S-K20 MAX	S-U15 MAX	S-15 MAX	S-K15 MAX
功率 Power	3HP	3HP	2HP	2HP	2HP
电压 Voltage	110V-120V	220V	110V-120V	220V-240V	220V
频率 Frequency	60Hz	60Hz	60Hz	50Hz	60Hz
压力 Pressure	3300Pa	3300Pa	2900Pa	2900Pa	2900Pa
流量 Flow	1300m ³ /h	1300m ³ /h	1080m ³ /h	1080m ³ /h	1080m ³ /h
线长 Cord Length	3M	3M	3M	3M	3M
认证 Certification	UL/CUL		UL/CUL	GS/CE/UKCA/SAA	
净重 N.W	12KG	12KG	11KG	11KG	11KG
毛重 G.W	13KG	13KG	12KG	12KG	12KG
包装尺寸 Packaging	41.8*30.8*46CM	41.8*30.8*46CM	41.8*30.8*46CM	41.8*30.8*46CM	41.8*30.8*46CM

MAX 风机系列

MAX SERIES

1HP 风机系列

1.5HP 风机系列

1500W / 1200W

出口风机系列

EXPORT BLOWER SERIES

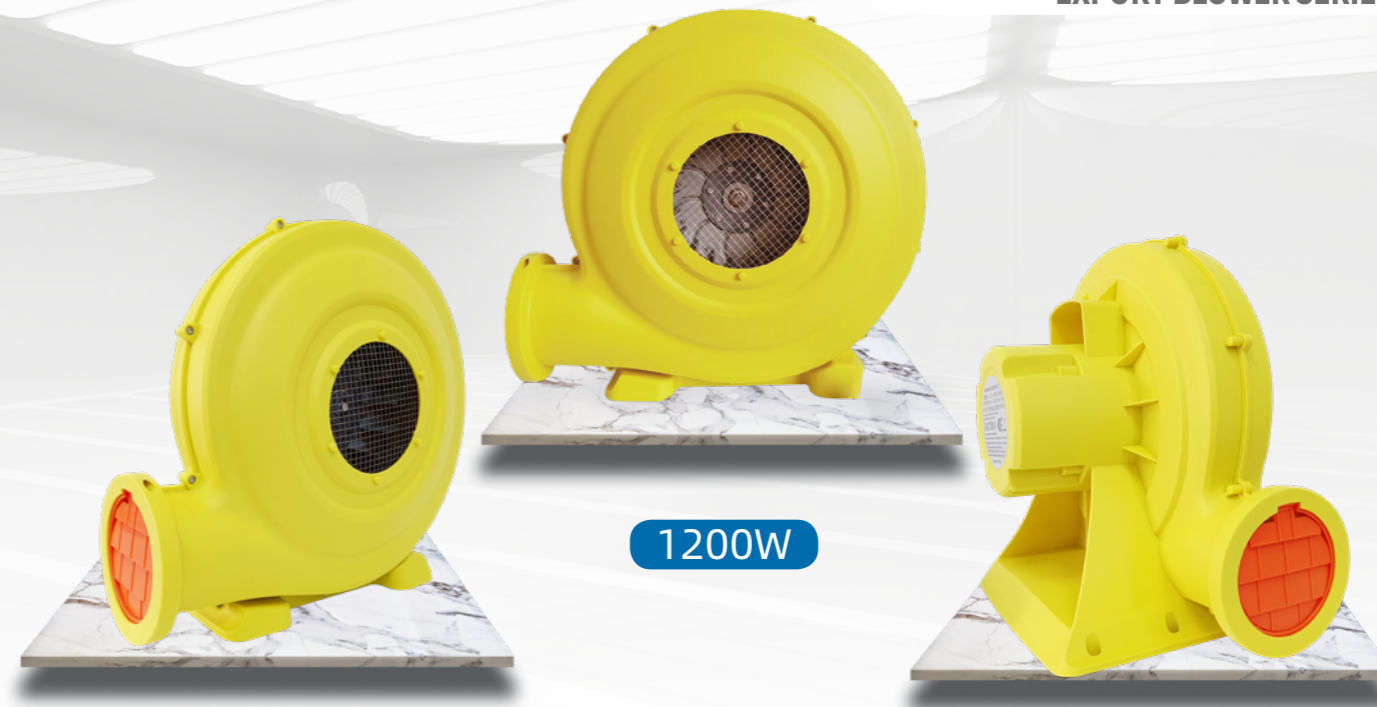
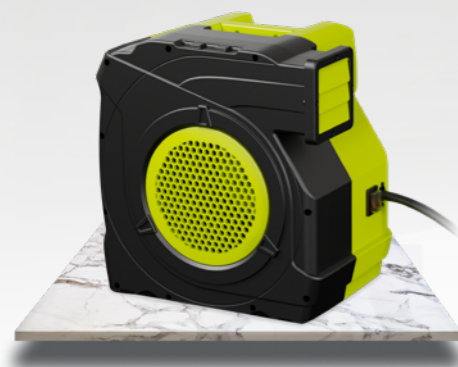

1HP 风机系列

1.5HP 风机系列

1500W

1200W

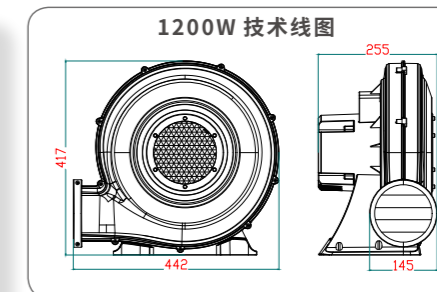
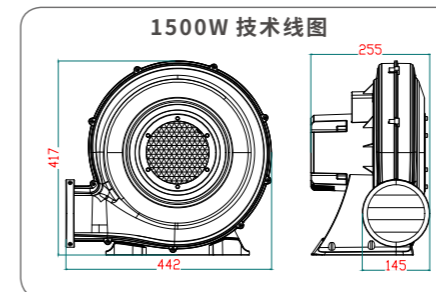
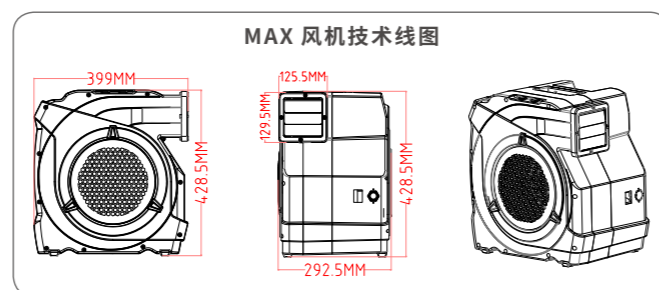

技术参数 TECHNICAL PARAMETERS

	1.5HP 风机系列			1HP 风机系列		
型号 Model	S-U12 MAX	S-12 MAX	S-K12 MAX	S-U9 MAX	S-9 MAX	S-K9 MAX
功率 Power	1.5HP	1.5HP	1.5HP	1HP	1HP	1HP
电压 Voltage	110V-120V	220V-240V	220V	110V-120V	220V-240V	220V
频率 Frequency	60Hz	50Hz	60Hz	60Hz	50Hz	60Hz
压力 Pressure	2700Pa	2700Pa	2700Pa	2350Pa	2350Pa	2350Pa
流量 Flow	980m ³ /h	980m ³ /h	980m ³ /h	890m ³ /h	890m ³ /h	890m ³ /h
线长 Cord Length	3M	3M	3M	3M	3M	3M
认证 Certification	UL/CUL	GS/CE/UKCA/SAA		UL/CUL	GS/CE/UKCA/SAA	
净重 N.W	10KG	10KG	10KG	9KG	9KG	9KG
毛重 G.W	11KG	11KG	11KG	10KG	10KG	10KG
包装尺寸 Packaging	41.8*30.8*46CM	41.8*30.8*46CM	41.8*30.8*46CM	41.8*30.8*46CM	41.8*30.8*46CM	41.8*30.8*46CM

技术参数 TECHNICAL PARAMETERS

型号 Model	S-U15	S-15	S-K15	S-U12	S-12	S-K12
功率 Power	1500W	1500W	1500W	1200W	1200W	1200W
电压 Voltage	110V-120V	220V-240V	220V	110V-120V	220V-240V	220V
频率 Frequency	60Hz	50Hz	60Hz	60Hz	50Hz	60Hz
压力 Pressure	2600Pa	2600Pa	2600Pa	2400Pa	2400Pa	2400Pa
流量 Flow	900m ³ /h	900m ³ /h	900m ³ /h	800m ³ /h	800m ³ /h	800m ³ /h
线长 Cord Length	3M	3M	3M	3M	3M	3M
认证 Certification	UL/CUL	GS/CE/UKCA/SAA		UL/CUL	GS/CE/UKCA/SAA	
净重 N.W	10KG	10KG	10KG	9KG	9KG	9KG
毛重 G.W	11KG	11KG	11KG	10KG	10KG	10KG
包装尺寸 Packaging	46*27.5*44.5CM			46*27.5*44.5CM		

出口风机系列

EXPORT BLOWER SERIES

950W 750W

550W 450W

出口风机系列

EXPORT BLOWER SERIES

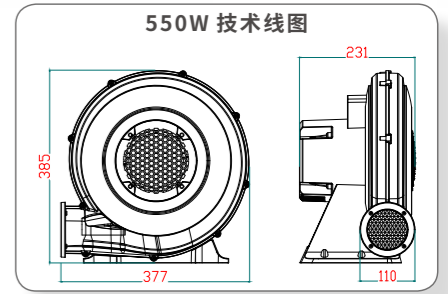
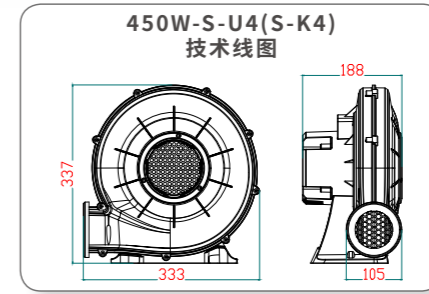
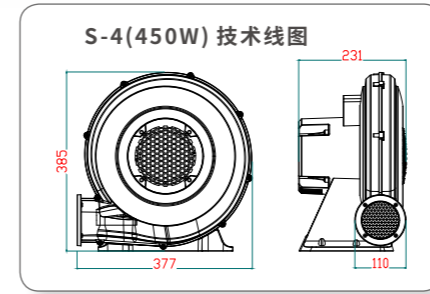
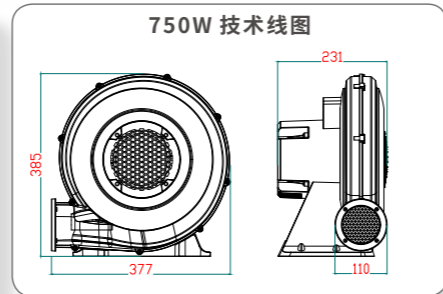
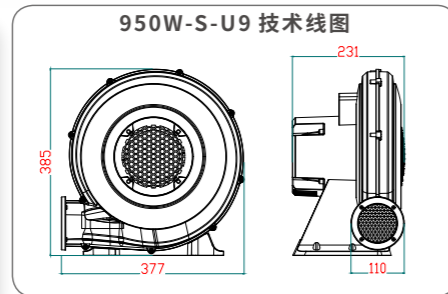
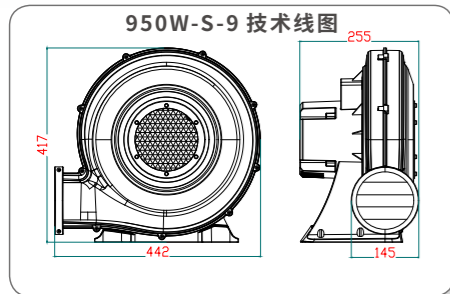

技术参数 TECHNICAL PARAMETERS

	950W 出口风机参数			750W 出口风机参数		
型号 Model	S-U9S	S-K9	S-9	S-U7S	S-7	S-K7
功率 Power	950W	950W	950W	750W	750W	750W
电压 Voltage	110V-120V	220V	220V-240V	110V-120V	220V-240V	220V
频率 Frequency	60Hz	60Hz	50Hz	60Hz	50Hz	60Hz
压力 Pressure	2250Pa	2250Pa	2250Pa	2050Pa	2050Pa	2050Pa
流量 Flow	690m³/h	690m³/h	690m³/h	590m³/h	590m³/h	590m³/h
线长 Cord Length	2M	2M	2M	2M	2M	2M
认证 Certification	UL/CUL		GS/CE/UKCA/SAA	UL/CUL	GS/CE/UKCA/SAA	
净重 N.W	7KG	7KG	7.5KG	6KG	6.5KG	6KG
毛重 G.W	8KG	8KG	8.5KG	7KG	7.5KG	7KG
包装尺寸 Packaging	39*25*41CM		46*27.5*44.5CM	39*25*41CM		

技术参数 TECHNICAL PARAMETERS

	550W 出口风机参数			450W 出口风机参数		
型号 Model	S-U5	S-5	S-K5	S-U4	S-4	S-K4
功率 Power	550W	550W	550W	450W	450W	450W
电压 Voltage	110V-120V	220V-240V	220V	110V-120V	220V-240V	220V
频率 Frequency	60Hz	50Hz	60Hz	60Hz	50Hz	60Hz
压力 Pressure	1950Pa	1950Pa	1950Pa	1750Pa	1750Pa	1750Pa
流量 Flow	520m³/h	520m³/h	520m³/h	450m³/h	450m³/h	450m³/h
线长 Cord Length	2M	2M	2M	2M	2M	2M
认证 Certification	UL/CUL	GS/CE/UKCA/SAA		UL/CUL	GS/CE/UKCA/SAA	
净重 N.W	5KG	5.5KG	5KG	3.5KG	5KG	3.5KG
毛重 G.W	6KG	6.5KG	6KG	4.5KG	6KG	4.5KG
包装尺寸 Packaging	39*25*41CM			35*21.5*37CM	39*25*41CM	35*21.5*37CM

出口风机系列

EXPORT BLOWER SERIES

350W

250W

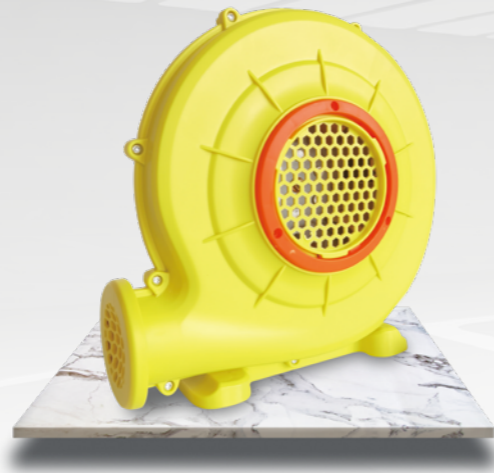

350W

250W

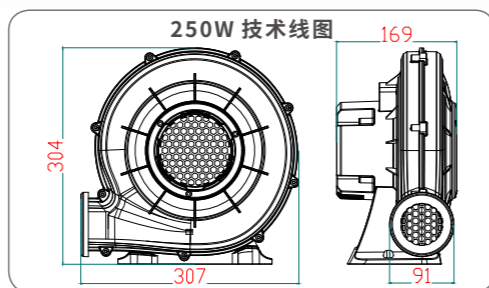
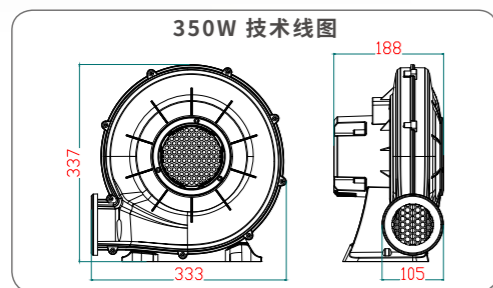

技术参数

TECHNICAL PARAMETERS

型号 Model	S-U3	S-3	S-K3	S-U2S	S-2	S-K2
功率 Power	350W	350W	350W	280W	250W	250W
电压 Voltage	110V-120V	220V-240V	220V	110V-120V	220V-240V	220V
频率 Frequency	60Hz	50Hz	60Hz	60Hz	50Hz	60Hz
压力 Pressure	1650Pa	1650Pa	1650Pa	1400Pa	1400Pa	1400Pa
流量 Flow	360m ³ /h	360m ³ /h	360m ³ /h	300m ³ /h	300m ³ /h	300m ³ /h
线长 Cord Length	2M	2M	2M	2M	2M	2M
认证 Certification	UL/CUL	GS/CE/UKCA/SAA		UL/CUL	GS/CE/UKCA/SAA	
净重 N.W	3KG	3.5KG	3KG	2.5KG	3KG	2.5KG
毛重 G.W	4KG	4.5KG	4KG	3KG	3.5KG	3KG
包装尺寸 Packaging	35*21.5*37CM			32*18.5*33.5CM		

400W

300W

250W



外置风机

内置风机

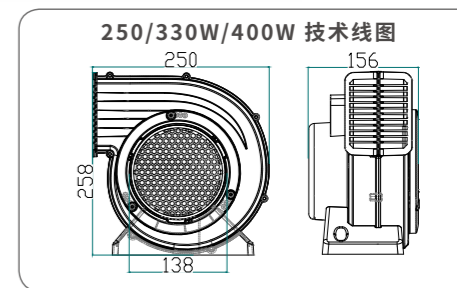

技术参数

TECHNICAL PARAMETERS

	400W 内置风机系列			330W 内置风机系列	250W 内置风机系列		
型号 Model	S-N4	S-NE4	S-KN4	S-NE3	S-N2S	S-NE2	S-KN2S
功率 Power	400W	400W	400W	330W	250W	250W	250W
电压 Voltage	110V-120V	220V-240V	220V	220V-240V	110V-120V	220V-240V	220V
频率 Frequency	60Hz	50Hz	60Hz	50Hz	60Hz	50Hz	60Hz
压力 Pressure	1350Pa	1350Pa	1350Pa	1200Pa	1000Pa	1000Pa	1000Pa
流量 Flow	400m ³ /h	400m ³ /h	400m ³ /h	350m ³ /h	300m ³ /h	300m ³ /h	300m ³ /h
线长 Cord Length	1.8M	1.8M	1.8M	1.8M	1.8M	1.8M	1.8M
认证 Certification		CE		CE			
进风口尺寸 size of air intake	13.8CM	13.8CM	13.8CM	13.8CM	13.8CM	13.8CM	13.8CM
净重 N.W	2.9KG	2.9KG	2.9KG	2.5KG	2KG	2KG	2KG
毛重 G.W	3.2KG	3.2KG	3.2KG	2.8KG	2.3KG	2.3KG	2.3KG
包装尺寸 Packaging	26*16*26.5CM			26*16*26.5CM	26*16*26.5CM		

出口风机系列

EXPORT BLOWER SERIES

200W

150W

100W

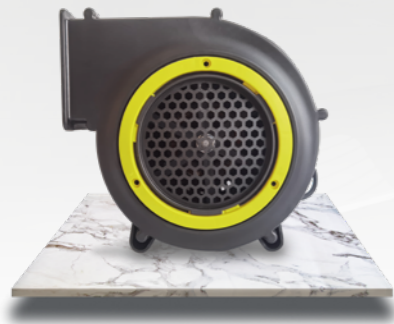

200W



100W



150W

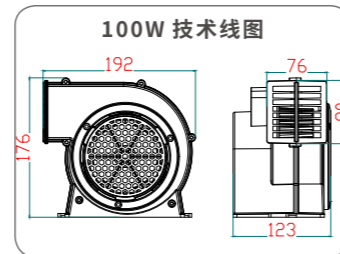
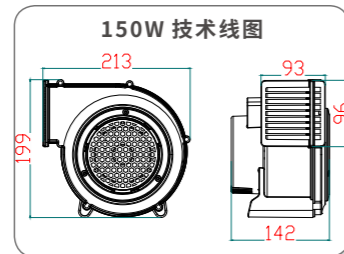
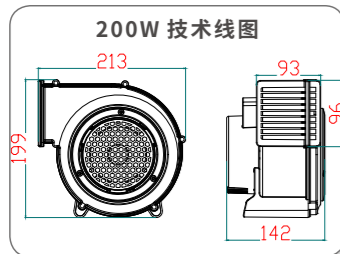

技术参数 TECHNICAL PARAMETERS

型号 Model	S-N2	S-KN2	S-E1.5	S-N1	S-E1	S-KN1
功率 Power	200W	200W	150W	120W	100W	100W
电压 Voltage	110V-120V	220V	220V-240V	110V-120V	220V-240V	220V
频率 Frequency	60Hz	60Hz	50Hz	60Hz	50Hz	60Hz
压力 Pressure	800Pa	800Pa	700Pa	600Pa	500Pa	600Pa
流量 Flow	200m ³ /h	200m ³ /h	160m ³ /h	120m ³ /h	100m ³ /h	120m ³ /h
线长 Cord Length	1.8M	1.8M	1.8M	1.8M	1.8M	1.8M
认证 Certification	UL/CUL		CE	UL/CUL	CE	
进风口尺寸 size of air intake	10.8CM	10.8CM	10.8CM	10.8CM	10.8CM	10.8CM
净重 N.W	1.6KG	1.6KG	1.6KG	1.3KG	1.3KG	1.3KG
毛重 G.W	2KG	2KG	2KG	1.6KG	1.6KG	1.6KG
包装尺寸 Packaging	22*14.5*21CM			20*13*19CM	20*13*19CM	

底盘灯光风机

150W



直径 Diameter: 63cm



直径 Diameter: 63cm

底盘灯光风机技术线图

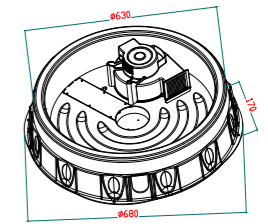

技术参数 TECHNICAL PARAMETERS

型号 Model	S-63U1	S-63E1	S-63K1	S-63J1
功率 Power	150W	150W	150W	150W
电压 Voltage	110V-120V	220V-240V	220V	100V
频率 Frequency	60Hz	50Hz	60Hz	50Hz/60Hz
压力 Pressure	700Pa	700Pa	700Pa	700Pa
流量 Flow	160m ³ /h	160m ³ /h	160m ³ /h	160m ³ /h
配件 Accessories	35W LED light	35W LED light	35W LED light	35W LED light
线长 Cord Length	1.8M	1.8M	1.8M	1.8M
净重 N.W	4.5KG	4.5KG	4.5KG	4.5KG
毛重 G.W	5.5KG	5.5KG	5.5KG	5.5KG
包装尺寸 Packaging	68*17*67CM	68*17*67CM	68*17*67CM	68*17*67CM

应用场景

APPLICATION SCENARIOS

适用范围广泛·针对不同场景而设计



强力电机 · 国际品质

POWERFUL MOTOR AND INTERNATIONAL QUALITY

高质量电机运转·经久耐用
 强劲内核带来持续稳定的风压运行。

气模广告风机系列

INFLATABLE ADVERTISING FAN SERIES

100W 180W 250W



180W



250W/330W/400W



100W



250W/330W/400W

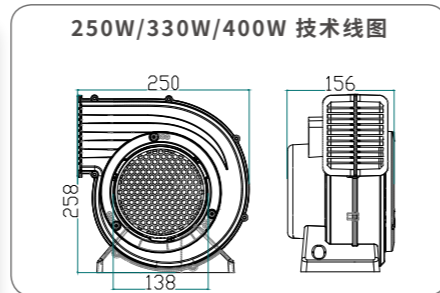
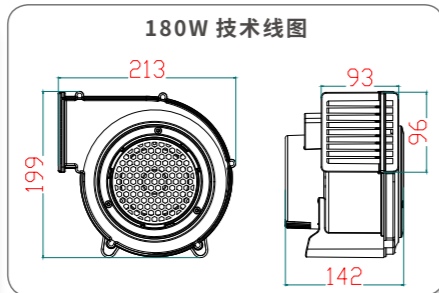
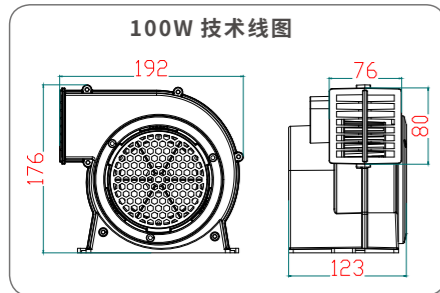

技术参数 TECHNICAL PARAMETERS

型号 Model	100W 塑料风机 (内外两用)	180 塑料风机 (内外两用)	250W 塑料风机 (内外两用)	330W 塑料风机 (内外两用)	400W 塑料风机 (内外两用)
功率 Power	100W	180W	250W	330W	400W
电压 Voltage	220V	220V	220V	220V	220V
频率 Frequency	50Hz	50Hz	50Hz	50Hz	50Hz
压力 Pressure	500Pa	600Pa	1100Pa	1200Pa	1350Pa
流量 Flow	100m ³ /h	150m ³ /h	250m ³ /h	350m ³ /h	400m ³ /h
线长 Cord Length	1M	1M	1M	1M	1M
进风口尺寸 size of air intake	10.8CM	10.8CM	13.8CM	13.8CM	13.8CM
净重 N.W	1.3KG	1.5KG	2KG	2.9KG	2.9KG
毛重 G.W	1.6KG	1.8KG	2.6KG	3.2KG	3.2KG
包装尺寸 Packaging	20*13*19CM	20*13*19CM	26*16*26.5CM	26*16*26.5CM	26*16*26.5CM

380W 550W 塑机 A 款 / B 款

气模广告风机系列

INFLATABLE ADVERTISING FAN SERIES



250W



380W



550W 塑机 A 款



550W 塑机 B 款

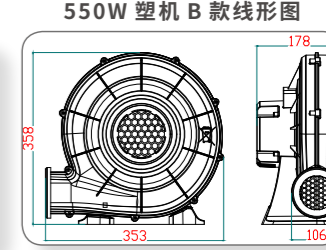
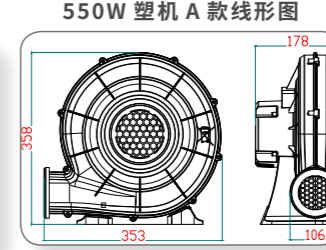
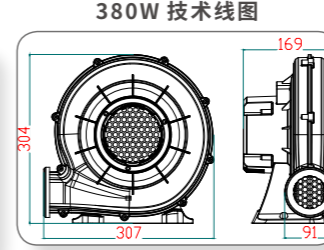
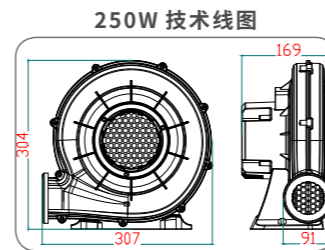

技术参数 TECHNICAL PARAMETERS

型号 Model	250W 塑料风机 (内外两用)	380W 塑料风机 (内外两用)	550W 塑料风机 A 款	550W 塑料风机 B 款
功率 Power	250W	380W	550W 塑机 A 款	550W 塑机 B 款
电压 Voltage	220V	220V	220V	220V
频率 Frequency	50Hz	50Hz	50Hz	50Hz
压力 Pressure	1100Pa	1300Pa	1600Pa	1500Pa
流量 Flow	250m ³ /h	300m ³ /h	400m ³ /h	350m ³ /h
线长 Cord Length	1M	1M	1M	1M
净重 N.W	2KG	2.8KG	3.5KG	3.2KG
毛重 G.W	2.6KG	3.2KG	3.9KG	3.6KG
包装尺寸 Packaging	31*16.5*32CM	31*16.5*32CM	35.5*17.5*36.5CM	35.5*17.5*36.5CM

气模广告风机系列

INFLATABLE ADVERTISING FAN SERIES

680W

750W

63CM 圆盘灯光风机



680W 塑机



750W 塑机



底盘灯光风机

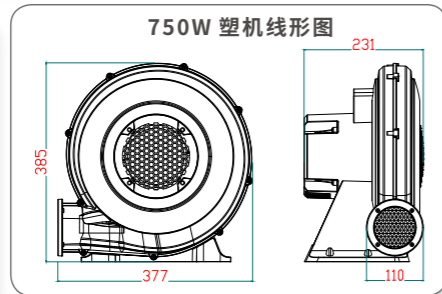
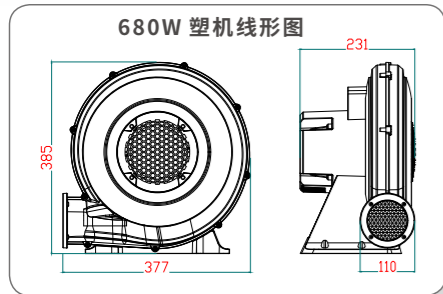

技术参数 TECHNICAL PARAMETERS

型号 Model	680W 塑料风机	750W 塑料风机	63CM 圆盘灯光风机
功率 Power	680W	750W	150W (35W 白灯 / 彩灯)
电压 Voltage	220V	220V	220V
频率 Frequency	50Hz	50Hz	50Hz
压力 Pressure	1750Pa	1900Pa	600Pa
流量 Flow	450m ³ /h	550m ³ /h	120m ³ /h
线长 Cord Length	1M	1M	1M
净重 N.W	5KG	5.5KG	4.5KG
毛重 G.W	5.5KG	6.5KG	5KG
包装尺寸 Packaging	38*23*42CM	38*23*42CM	68*17*67CM

950W

1100W

1500W 塑机

气模广告风机系列

INFLATABLE ADVERTISING FAN SERIES



950W 塑机



1100W 塑机



1500W 塑机

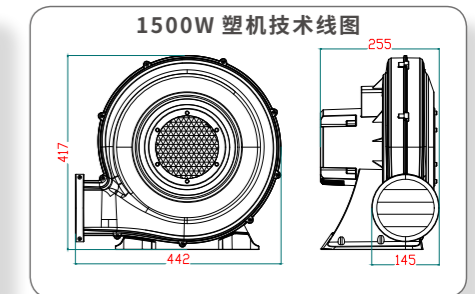
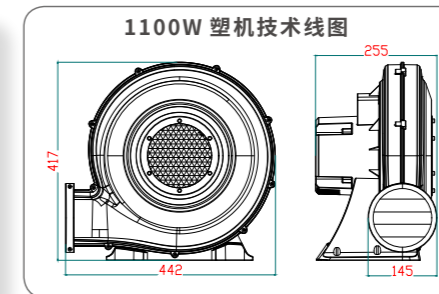
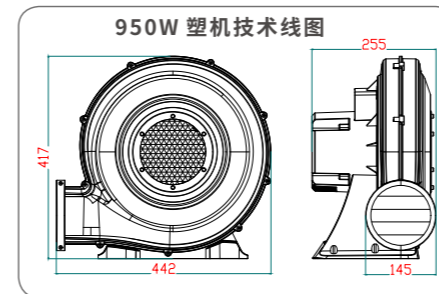

技术参数 TECHNICAL PARAMETERS

型号 Model	950W 塑料风机	1100W 塑料风机	1500W 塑料风机
功率 Power	950W	1100W	1500W
电压 Voltage	220V	220V	220V
频率 Frequency	50Hz	50Hz	50Hz
压力 Pressure	2200Pa	2400Pa	2600Pa
流量 Flow	680m ³ /h	800m ³ /h	900m ³ /h
线长 Cord Length	2M	2M	2M
净重 N.W	7.5KG	8.5KG	9.5KG
毛重 G.W	8.5KG	9.5KG	10.5KG
包装尺寸 Packaging	46*27.5*44.5CM	46*27.5*44.5CM	46*27.5*44.5CM

气模广告风机系列

INFLATABLE ADVERTISING FAN SERIES

1100W-1500W 风口在上塑机
1500W-1800W MAX 塑料风机

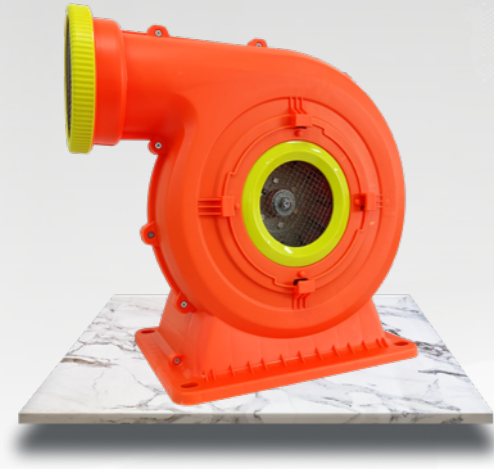

1100W-1500W 风口在上塑机



1500W 塑机
1800W 塑机

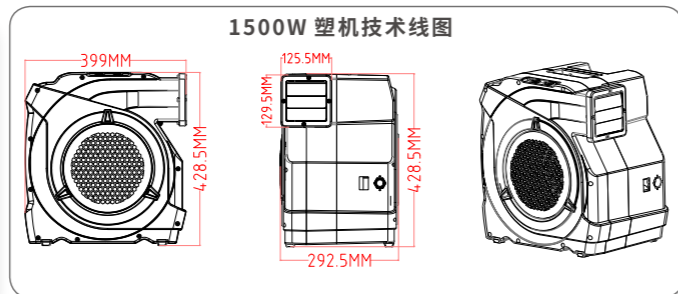
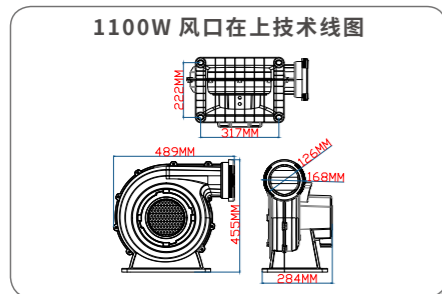

技术参数 TECHNICAL PARAMETERS

型号 Model	1100W 风口在上塑机	1500W 风口在上塑机	1500W MAX 塑料风机	1800W MAX 塑料风机
功率 Power	1100W	1500W	1500W MAX	1800W MAX
电压 Voltage	220V	220V	220V	220V
频率 Frequency	50Hz	50Hz	50Hz	50Hz
压力 Pressure	2200Pa	2400Pa	2800Pa	3100Pa
流量 Flow	780m ³ /h	880m ³ /h	950m ³ /h	1000m ³ /h
线长 Cord Length	2M	2M	2.15M	2.15M
净重 N.W	9KG	10KG	11KG	12KG
毛重 G.W	10KG	11KG	12KG	13KG
包装尺寸 Packaging	56.5*31*54.5CM		41.8*30.8*46CM	

250W 铁机 / 370W 离心机
370W 新款离心机

气模广告风机系列

INFLATABLE ADVERTISING FAN SERIES



250W 铁机



370W 离心机



370W 新款离心机

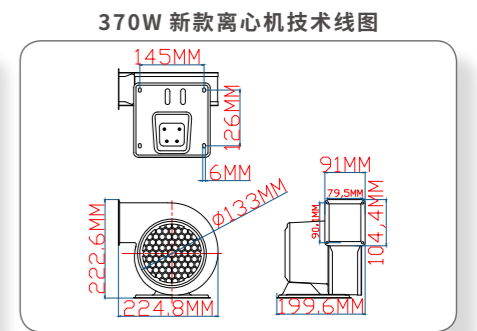
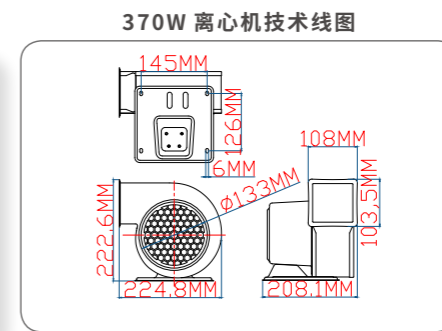
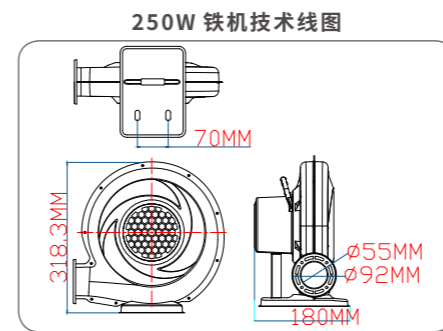

技术参数 TECHNICAL PARAMETERS

型号 Model	250W 铁机	370W 离心机	370W 内置离心机
功率 Power	250W	370W	370W
电压 Voltage	220V	220V	220V
频率 Frequency	50Hz	50Hz	50Hz
压力 Pressure	1100Pa	2400Pa	2600Pa
流量 Flow	250m ³ /h	360m ³ /h	360m ³ /h
线长 Cord Length	1M	1M	1M
净重 N.W	3.5KG	3KG	3KG
毛重 G.W	4.5KG	4KG	4KG
包装尺寸 Packaging	32*19*32CM	23.5*21.3*23.5CM	23.5*21.3*23.5CM

气模广告风机系列

INFLATABLE ADVERTISING FAN SERIES

550W 铁机 A 款

680W 铁机

550W 铁机 C 款

750W 铁机 / 950W 铁机

1100W 铁机

气模广告风机系列

INFLATABLE ADVERTISING FAN SERIES



550W 铁机 A 款



550W 铁机 C 款



680W 铁机



750W 铁机



950W 铁机



1100W 铁机

550W 铁机 A 款技术线图

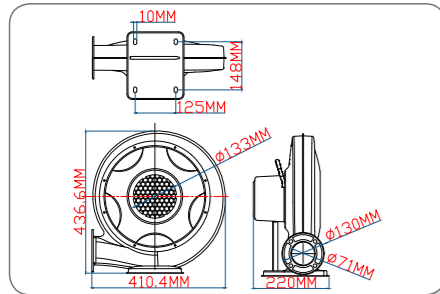

550W 铁机 C 款技术线图

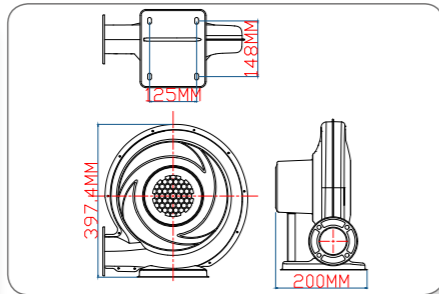

680W 铁机技术线图

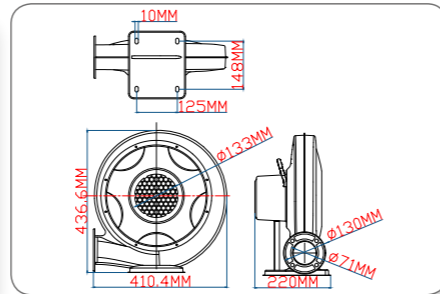

750W 铁机技术线图

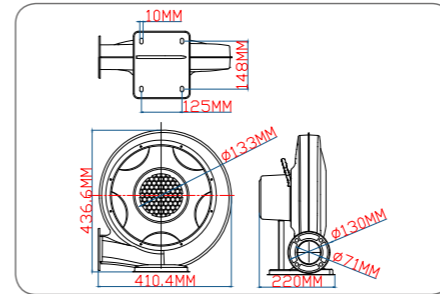

950W 铁机技术线图

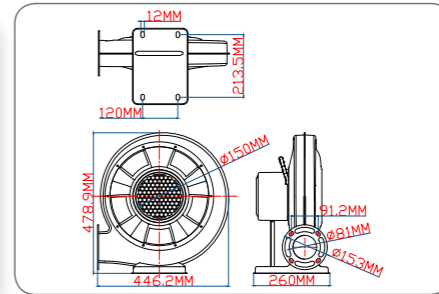

1100W 铁机技术线图

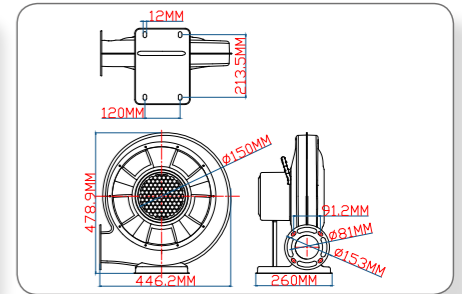

技术参数

TECHNICAL PARAMETERS

型号 Model	550W 铁机 A 款	550W 铁机 C 款	680W 铁机
功率 Power	550W	550W	680W
电压 Voltage	220V	220V	220V
频率 Frequency	50Hz	50Hz	50Hz
压力 Pressure	1600Pa	1500Pa	1750Pa
流量 Flow	400m ³ /h	380m ³ /h	450 m ³ /h
线长 Cord Length	1M	1M	1M
净重 N.W	5.5KG	5KG	7KG
毛重 G.W	6.5KG	5.8KG	7.3KG
包装尺寸 Packaging	42.5*21.5*46.5CM	40.5*21*42CM	42.5*23.5*46.5CM

技术参数

TECHNICAL PARAMETERS

型号 Model	750W 铁机	950W 铁机	1100W 铁机
功率 Power	750W	950W	1100W
电压 Voltage	220V	220V	220V
频率 Frequency	50Hz	50Hz	50Hz
压力 Pressure	1900Pa	2200Pa	2400Pa
流量 Flow	550m ³ /h	680m ³ /h	780m ³ /h
线长 Cord Length	1M	1M	1M
净重 N.W	7.3KG	8KG	9KG
毛重 G.W	8KG	9KG	10KG
包装尺寸 Packaging	42.5*23.5*46.5CM	46*28.3*51CM	46*28.3*51CM

厨具风机系列

KITCHEN FAN SERIES

厨具专用中压风机

助燃 / 冷却 / 工业 / 鼓风

70W 节能机 120W 菊花机
180W 菊花机

250W 280W 370W

厨具风机系列

KITCHEN FAN SERIES



70W 节能机



120W 菊花机



180W 菊花机



280W 厨具铁机

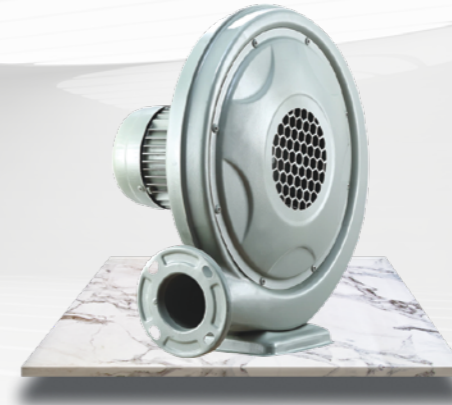

250W 厨具铁机



370W 厨具铁机

70W 节能机技术线图

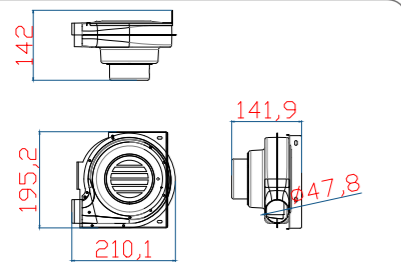

120W 菊花机技术线图

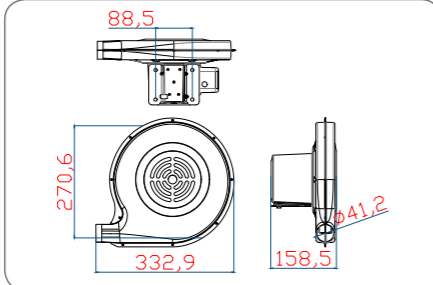

180W 菊花机技术线图

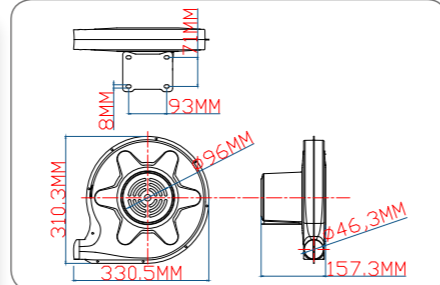

250W 厨具铁机技术线图

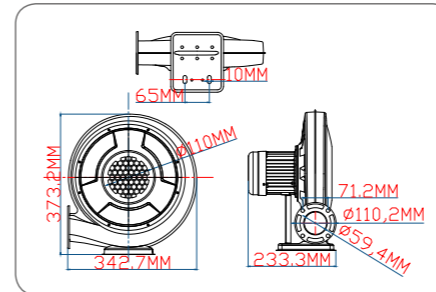

280W 厨具铁机技术线图

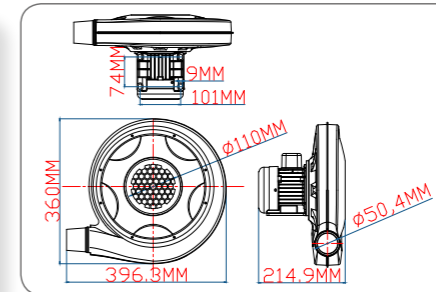

370W 厨具铁机技术线图

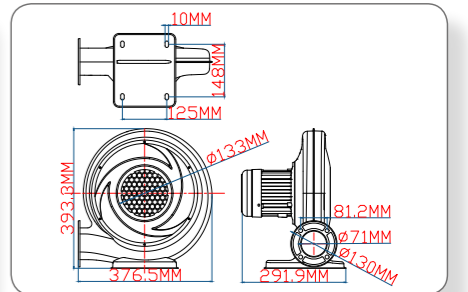

技术参数 TECHNICAL PARAMETERS

型号 Model	70W 节能风机	120W 菊花风机	180W 菊花风机
功率 Power	70W	120W	180W
电压 Voltage	110V/220V/380V	110V/220V/380V	110V/220V/380V
频率 Frequency	50Hz/60Hz	50Hz/60Hz	50Hz/60Hz
压力 Pressure	500Pa	1100Pa	1200Pa
流量 Flow	100m ³ /h	320m ³ /h	350m ³ /h
净重 N.W	2KG	3KG	4KG
毛重 G.W	2.5KG	4KG	4.5KG

技术参数 TECHNICAL PARAMETERS

型号 Model	250W 厨具铁机	280W 厨具铁机	370W 厨具铁机
功率 Power	250W	280W	370W
电压 Voltage	110V/220V/380V	110V/220V/380V	110V/220V/380V
频率 Frequency	50Hz/60Hz	50Hz/60Hz	50Hz/60Hz
压力 Pressure	1300Pa	1450Pa	1600Pa
流量 Flow	600m ³ /h	600m ³ /h	700m ³ /h
净重 N.W	5.5KG	5.5KG	8.5KG
毛重 G.W	6KG	6KG	9KG
包装尺寸 Packaging	34.5*24*39.5CM	34.5*24*39.5CM	39.5*28*46.5CM

厨具风机系列

KITCHEN FAN SERIES

550W 厨具铁机 / 750W 厨具铁机
750W 厨具铁机 (小款)



550W 厨具铁机



750W 厨具铁机 (小款)



750W 厨具铁机

550W 厨具铁机技术线图

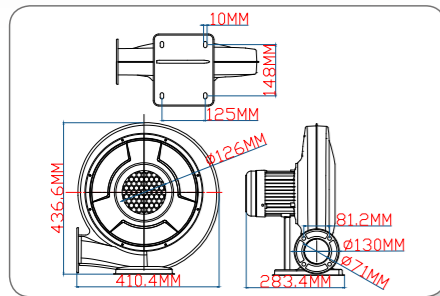

750W 厨具铁机 (小款) 技术线图

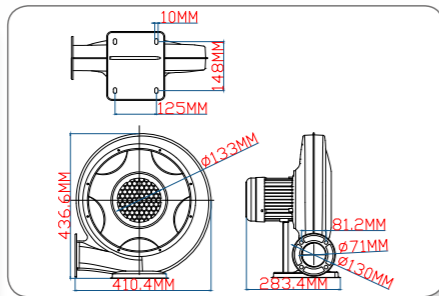

750W 厨具铁机技术线图

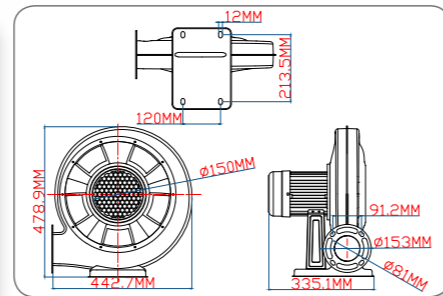

技术参数

TECHNICAL PARAMETERS

型号 Model	550W 厨具铁机	750W 厨具铁机 (小款)	750W 厨具铁机
功率 Power	550W	750W	750W
电压 Voltage	110V/220V/380V	110V/220V/380V	110V/220V/380V
频率 Frequency	50Hz/60Hz	50Hz/60Hz	50Hz/60Hz
压力 Pressure	1900Pa	2200Pa	2350Pa
流量 Flow	850m ³ /h	880m ³ /h	900m ³ /h
净重 N.W	9KG	10KG	12KG
毛重 G.W	9.6KG	11KG	13KG
包装尺寸 Packaging	41*29*46.5CM	41*31*46.5CM	46*35.2*50CM

250W / 370W / 550W
750W / 950W 厨具铝机

厨具风机系列

KITCHEN FAN SERIES



250W 厨具铝机



370-550W 厨具铝机



750W 厨具铝机



950W 厨具铝机

250W 厨具铝机技术线图

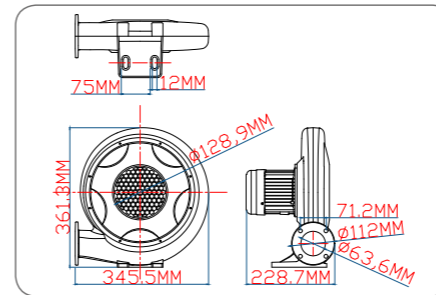

370W-550W 厨具铝机技术线图

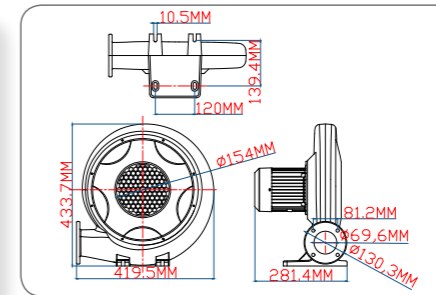

750W-950W 厨具铝机技术线图

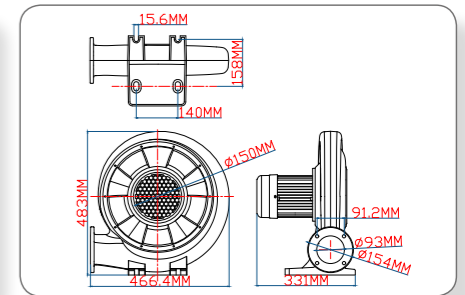

技术参数

TECHNICAL PARAMETERS

型号 Model	250W 厨具铝机	370W-550W 厨具铝机	750W-950W 厨具铝机
功率 Power	250W	370W-550W	750W-950W
电压 Voltage	110V/220V/380V	110V/220V/380V	110V/220V/380V
频率 Frequency	50Hz/60Hz	50Hz/60Hz	50Hz/60Hz
压力 Pressure	1300Pa	1900Pa	2350Pa
流量 Flow	600m ³ /h	850m ³ /h	900m ³ /h
净重 N.W	10KG	12KG	13KG
毛重 G.W	11KG	13KG	14KG
包装尺寸 Packaging	36*26*38.5CM	41*31*46.5CM	46*35.2*50CM

激光雕刻风机

LASER ENGRAVING FAN

250W 370W 550W

750W (小款) 750W 950W

激光雕刻风机

LASER ENGRAVING FAN



250W 激光雕刻风机



370W 激光雕刻风机



550W 激光雕刻风机



750W 小款激光雕刻风机



750W 激光雕刻风机



950W 激光雕刻风机

250W 激光雕刻风机技术线图

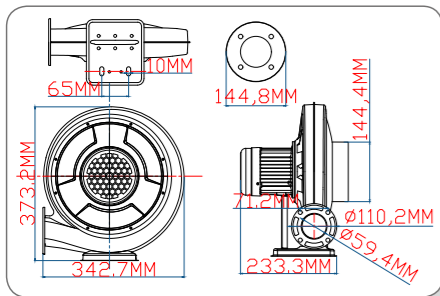

370W 激光雕刻风机技术线图

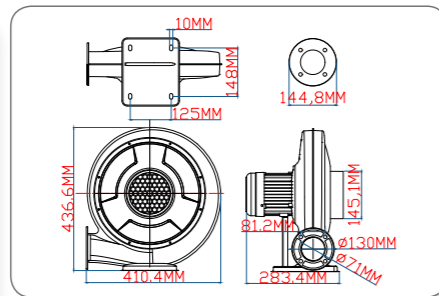

550W 激光雕刻风机技术线图

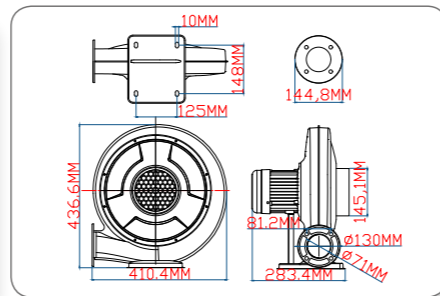

750W 小款激光雕刻风机技术线图

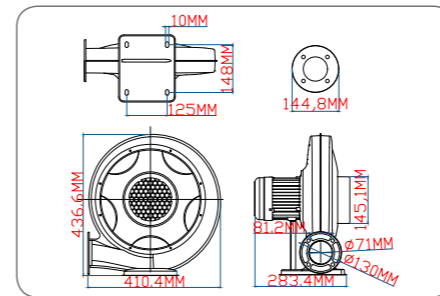

750W 激光雕刻风机技术线图

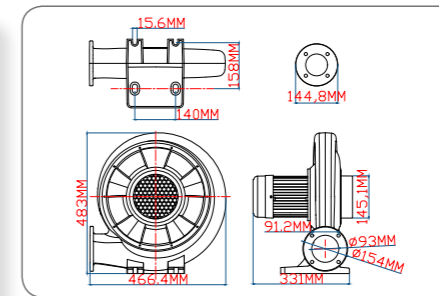

950W 激光雕刻风机技术线图

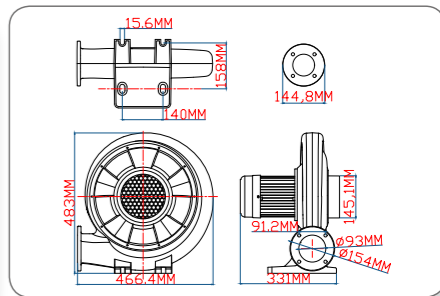

技术参数 TECHNICAL PARAMETERS

型号 Model	250W 激光雕刻铁机	370W 激光雕刻铁机	550W 激光雕刻铁机
功率 Power	250W	370W	550W
电压 Voltage	110V/220V/380V	110V/220V/380V	110V/220V/380V
频率 Frequency	50Hz/60Hz	50Hz/60Hz	50Hz/60Hz
压力 Pressure	1300Pa	1600Pa	1900Pa
流量 Flow	600m ³ /h	700m ³ /h	850m ³ /h
净重 N.W	6KG	8.5KG	9KG
毛重 G.W	6.5KG	9KG	10KG
包装尺寸 Packaging	36*26*38.5CM	46*31*46.5CM	46*31*46.5CM

技术参数 TECHNICAL PARAMETERS

型号 Model	750W 激光雕刻铁机 (小款)	750W 激光雕刻铁机	950W 激光雕刻铁机
功率 Power	750W	750W	950W
电压 Voltage	110V/220V/380V	110V/220V/380V	110V/220V/380V
频率 Frequency	50Hz/60Hz	50Hz/60Hz	50Hz/60Hz
压力 Pressure	2200Pa	2250Pa	2350Pa
流量 Flow	880m ³ /h	880m ³ /h	900m ³ /h
净重 N.W	10KG	12KG	13KG
毛重 G.W	11KG	13KG	14KG
包装尺寸 Packaging	46*31*46.5CM	51*35.2*50CM	51*35.2*50CM

喷砂设备风机系列

SAND BLASTING EQUIPMENT FAN SERIES

250W 370W 550W



250W 喷砂铁机



370W 喷砂铁机



550W 喷砂铁机

250W 喷砂设备铁机技术线图

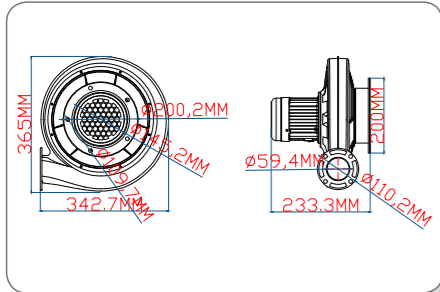

370W 喷砂设备铁机技术线图

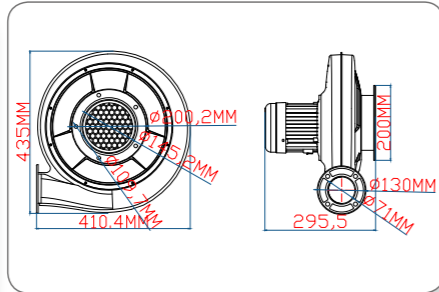

550W 喷砂设备铁机技术线图

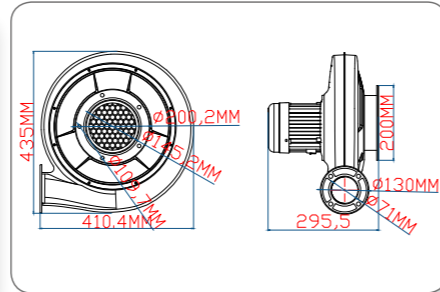

技术参数

TECHNICAL PARAMETERS

型号 Model	250W 喷砂铁机	370W 喷砂铁机	550W 喷砂铁机
功率 Power	250W	370W	550W
电压 Voltage	110V/220V/380V	110V/220V/380V	110V/220V/380V
频率 Frequency	50Hz/60Hz	50Hz/60Hz	50Hz/60Hz
压力 Pressure	1300Pa	1600Pa	1900Pa
流量 Flow	600m ³ /h	700m ³ /h	850m ³ /h
线长 Cord Length	1M	1M	1M
净重 N.W	5.5KG	8.5KG	9KG
毛重 G.W	6KG	9KG	9.6KG
包装尺寸 Packaging	37*26*38CM	43*31*45CM	46*35.2*50CM

750W (小款) 750W 950W

喷砂设备风机系列

SAND BLASTING EQUIPMENT FAN SERIES

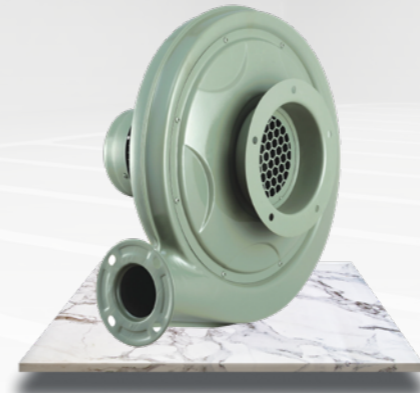

750W 喷砂铁机 (小款)



750W 喷砂铁机

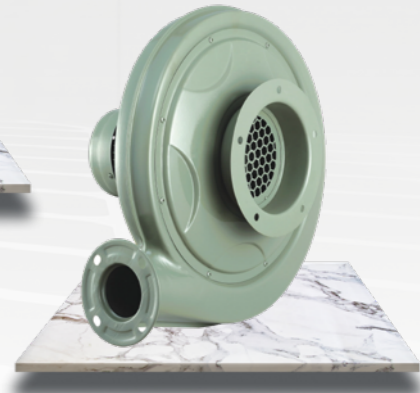

950W 喷砂铁机

750W 喷砂铁机小款技术线图

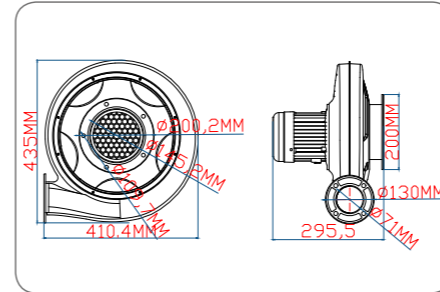

750W 喷砂设备铁机技术线图

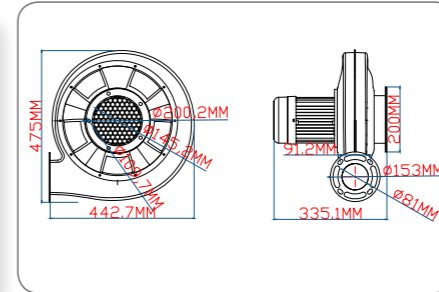

950W 喷砂设备铁机技术线图

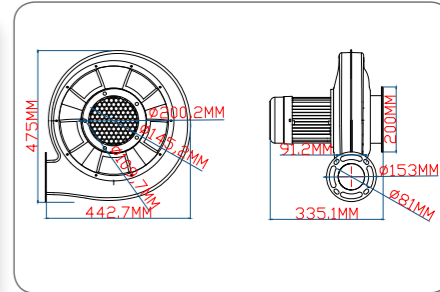

技术参数

TECHNICAL PARAMETERS

型号 Model	750W 喷砂铁机 (小款)	750W 喷砂铁机	950W 喷砂铁机
功率 Power	750W	750W	950W
电压 Voltage	110V/220V/380V	110V/220V/380V	110V/220V/380V
频率 Frequency	50Hz/60Hz	50Hz/60Hz	50Hz/60Hz
压力 Pressure	2200Pa	2250Pa	2350Pa
流量 Flow	880m ³ /h	880m ³ /h	900m ³ /h
线长 Cord Length	1M	1M	1M
净重 N.W	10KG	11KG	12KG
毛重 G.W	11KG	12KG	13KG
包装尺寸 Packaging	41*31*45CM	46*35.2*50CM	46*35.2*50CM

高压风机系列

HIGH PRESSURE FAN SERIES

1500W 2200W

全球销售

GLOBAL SALES

质量保障 寿命长

SINCERELY AT YOUR SERVICE

竭诚为您服务

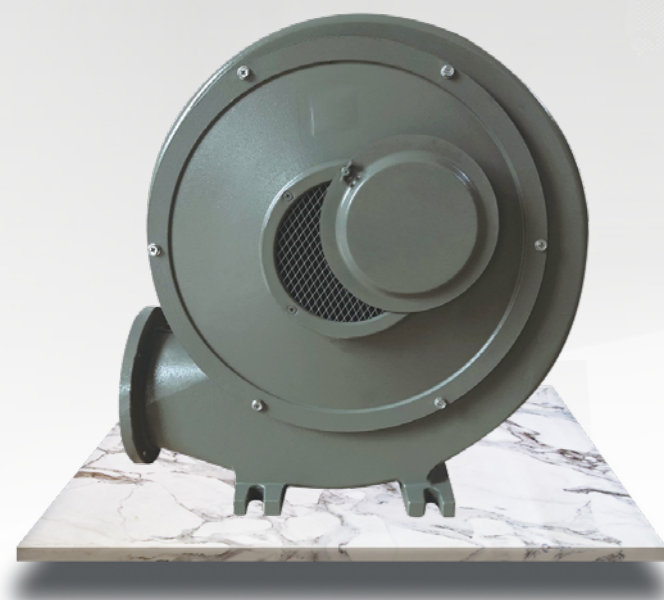

1500W 机械铝机

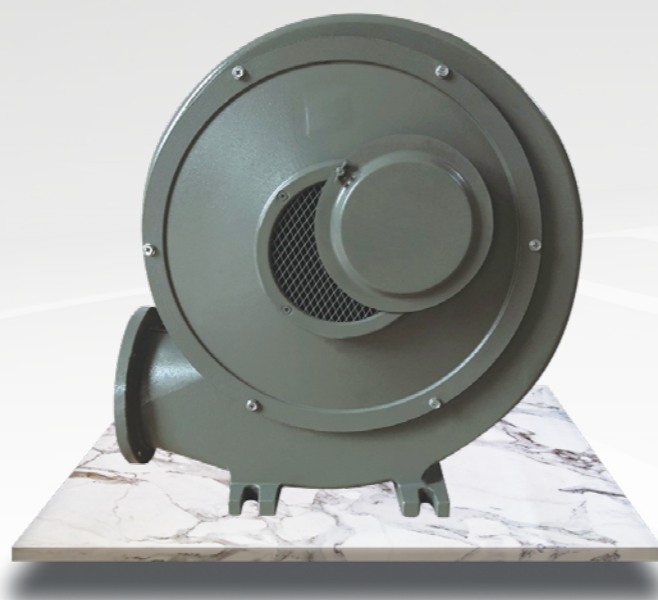

2200W 机械铝机



技术参数 TECHNICAL PARAMETERS

型号 Model	1500W 机械铝机	2200W 机械铝机
功率 Power	1500W	2200W
电压 Voltage	380V	380V
频率 Frequency	50Hz	50Hz
压力 Pressure	3000Pa	3350Pa
流量 Flow	1050 m ³ /h	1200m ³ /h
净重 N.W	23KG	25KG
产品尺寸 Product size	50*38*53CM	50*38*53CM

立足中国·服务全球

拓展国际市场 Expand International Markets

稳居国内市场，大步迈向国际市场。

本公司一向以立足中国，放眼世界为市场策略。

Stable in the domestic market and stride towards the international market.

The company has always been based in China and looking to the world as its market strategy.